

ALUCOBOND®

LIEFERPROGRAMM - Aluminium-Spezialprofile und Zubehör

PRODUCT RANGE - Aluminium Special Sections and Fittings

GAMME DE PRODUITS - Profilés spéciaux en aluminium et accessoires

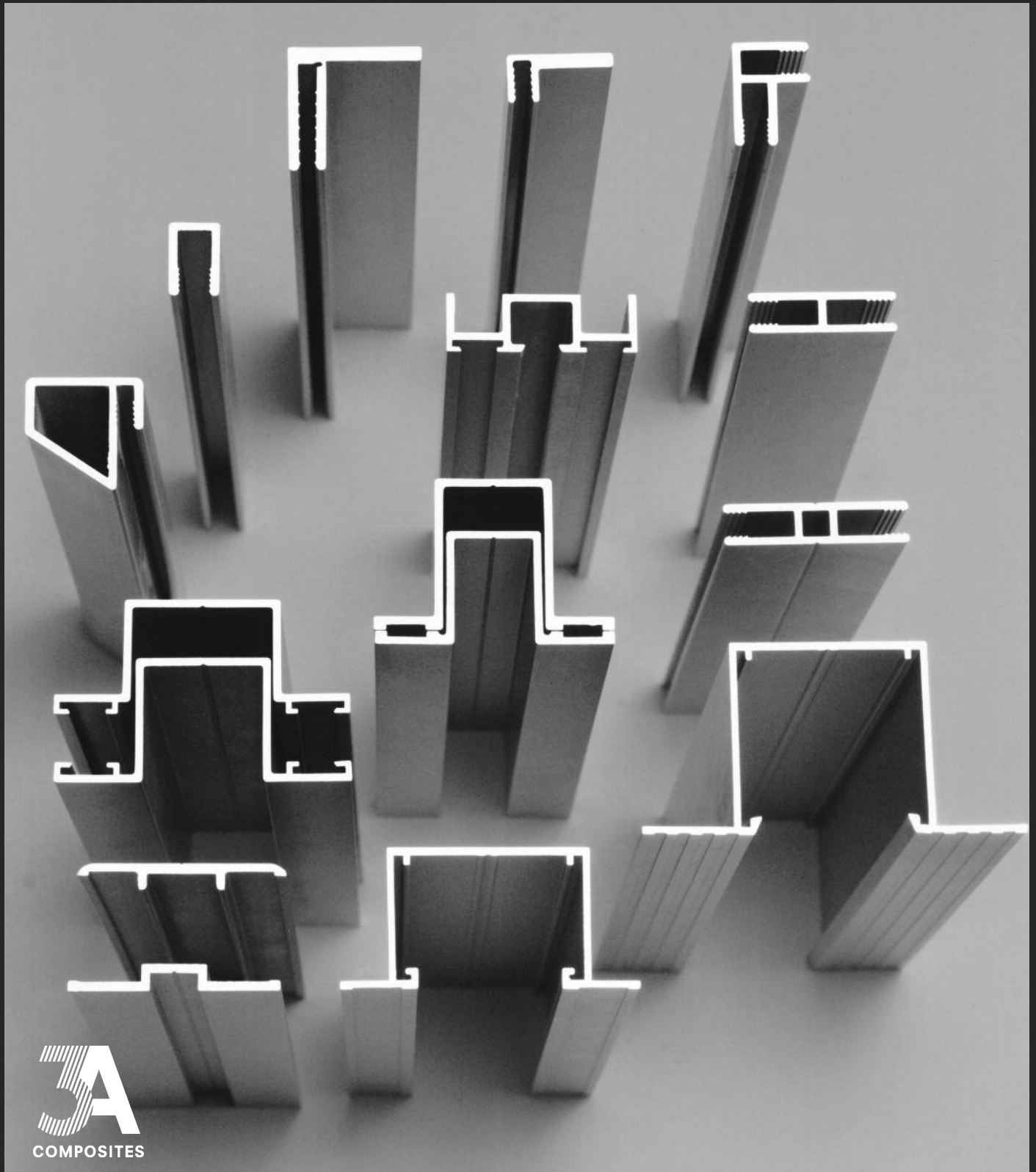

Aluminium-Spezialprofile für ALUCOBOND®
Aluminium Special Sections for ALUCOBOND®
Profils spéciaux en aluminium pour ALUCOBOND®

- 3 Abschlußprofile/Edge Sections/Profils de bordure
- 4 Eckverbindungsprofile/Corner-joint Sections/
Profils pour assemblage en angle
- 5-6 Stoßverbindungsprofile/Butt-joint Sections/
Profils assemblage bout à bout
- 7 Einfußprofile/Border Sections/Profils d'encastrement
- 8 Tragprofil "T 40"/Support Section "T 40"/
Profilé porteur "T 40"
- 8 Versteifungsprofil für Balkonplatten/
Reinforcing Section for Balcony Panels/
Profilé de renfort pour panneaux de balcon
- 9 Deckprofile/Cover Sections/Profils de recouvrement
- 9 Fensteranschlußprofil/Window Connection Section/
Profilé de jonction pour fenêtre
- 10-12 Hutprofile/Hat Sections/Profils capot oméga
- 13-16 ECOCLAD-Profil/ECOCLAD-Sections/Profils ECOCLAD
- 17-18 Kassettenprofil SZ 20/Sections for Tray Panels SZ 20/
Profils pour cassettes SZ 20

Lieferprogramm Produkt Range Gamme de produits

Werkstoff/Alloy/ Matière:
ANTICORODAL-045 (AlMgSi_{0,5}), EN AW-6060

Zustand/Temper/Etat:
T6 nach/acc. to/selon DIN EN 755-1
Eloxalqualität/Anodizing quality/Qualité anodisation

Oberfläche/Surface/Etat de surface:
Preßblank/As-extruded/Brut de filage

Lagerlängen/Stock lengths/Longueur en stock:
ca./ca./env. 6000 mm

Gewicht/ Weight/ Poids.	Abwicklung/ Periphery/ Développé.	Sichtfläche/ Visible periphery/ Périmètre visible.
kg/m	mm	mm

Abschlußprofile/ Edge Sections/ Profilés de bordure

für../for../pour.. ALUCOBOND®
3 mm
Profil Nr./Section No./Profilé No.
24554

M/Scale/Ech.
1:1

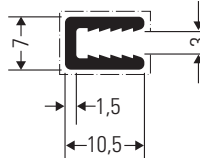

0,110	57	28
-------	----	----

für../for../pour.. ALUCOBOND®
4 mm
Profil Nr./Section No./Profilé No.
24494

M/Scale/Ech.
1:1

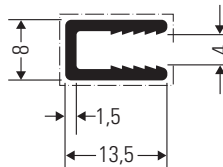

0,140	72	35
-------	----	----

für../for../pour.. ALUCOBOND®
6 mm
Profil Nr./Section No./Profilé No.
24561

M/Scale/Ech.
1:1

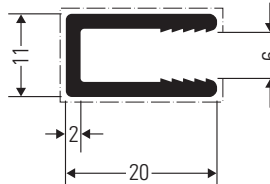

0,273	102	51
-------	-----	----

für../for../pour.. ALUCOBOND®
8 mm
Profil Nr./Section No./Profilé No.
24569

M/Scale/Ech.
1:1

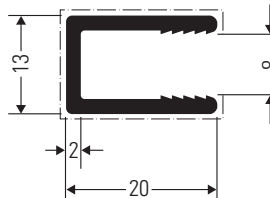

0,285	106	53
-------	-----	----

Lieferprogramm Produkt Range Gamme de produits

Werkstoff/Alloy/ Matière:
ANTICORODAL-045 (AlMgSi_{0,5}), EN AW-6060

Zustand/Temper/Etat:
T6 nach/acc. to/selon DIN EN 755-1
Eloxalqualität/Anodizing quality/Qualité anodisation

Oberfläche/Surface/Etat de surface:
Preßblank/As-extruded/Brut de filage

Lagerlängen/Stock lengths/Longueur en stock:
ca./ca./env. 6000 mm

Gewicht/ Weight/ Poids.	Abwicklung/ Periphery/ Développé.	Sichtfläche/ Visible periphery/ Périmètre visible.
kg/m	mm	mm

Eckverbindungsprofile/ Corner-joint sections/ Profils pour assemblage en angle

für../for../pour.. ALUCOBOND®
3 mm
Profil Nr./Section No./Profilé No.
24556

M/Scale/Ech.
1:1

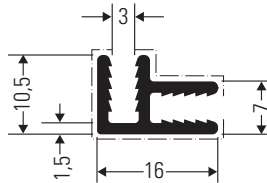

0,195	98	40
-------	----	----

für../for../pour.. ALUCOBOND®
4 mm
Profil Nr./Section No./Profilé No.
24552

M/Scale/Ech.
1:1

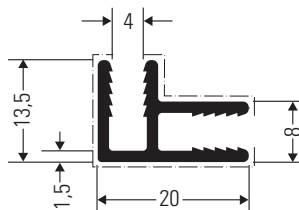

0,245	124	51
-------	-----	----

für../for../pour.. ALUCOBOND®
6 mm
Profil Nr./Section No./Profilé No.
24563

M/Scale/Ech.
1:1

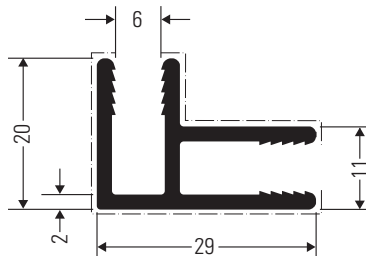

0,466	179	76
-------	-----	----

für../for../pour.. ALUCOBOND®
8 mm
Profil Nr./Section No./Profilé No.
24571

M/Scale/Ech.
1:1

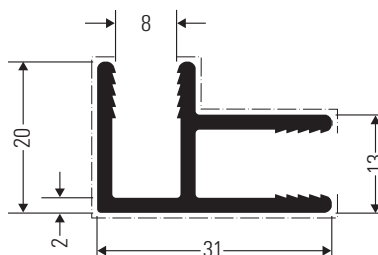

0,476	183	76
-------	-----	----

Lieferprogramm
Produkt Range
Gamme de produits

Werkstoff/Alloy/ Matière:
 ANTICORODAL-045 (AlMgSi_{0,5}), EN AW-6060
 Zustand/Temper/Etat:
 T6 nach/acc. to/selon DIN EN 755-1
 Eloxaqualität/Anodizing quality/Qualité anodisation
 Oberfläche/Surface/Etat de surface:
 Preßblank/As-extruded/Brut de filage
 Lagerlängen/Stock lengths/Longueur en stock:
 ca./ca./env. 6000 mm

Gewicht/ Weight/ Poids.	Abwicklung/ Periphery/ Développé.	Sichtfläche/ Visible periphery/ Périmètre visible.
kg/m	mm	mm

**Stoßverbindungsprofile/
 Butt-joint sections/
 Profilés pour assemblage bout à bout**

für../for../pour.. ALUCOBOND®
 3 mm
Profil Nr./Section No./Profilé No.
24555

M/Scale/Ech.
 1:1

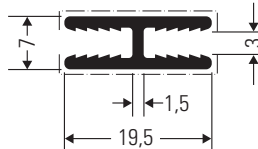

0,195	94	39
-------	----	----

für../for../pour.. ALUCOBOND®
 4 mm
Profil Nr./Section No./Profilé No.
24551

M/Scale/Ech.
 1:1

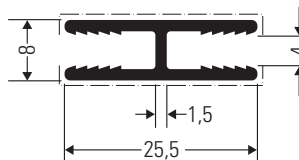

0,247	124	51
-------	-----	----

für../for../pour.. ALUCOBOND®
 6 mm
Profil Nr./Section No./Profilé No.
24562

M/Scale/Ech.
 1:1

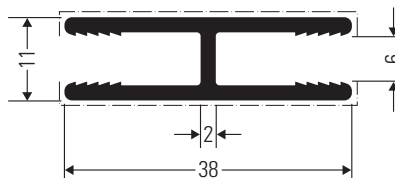

0,466	180	76
-------	-----	----

für../for../pour.. ALUCOBOND®
 8 mm
Profil Nr./Section No./Profilé No.
24570

M/Scale/Ech.
 1:1

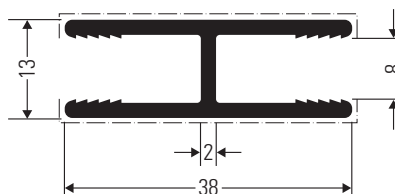

0,476	183	76
-------	-----	----

Lieferprogramm Produkt Range Gamme de produits

Werkstoff/Alloy/ Matière:
ANTICORODAL-045 (AlMgSi_{0,5}), EN AW-6060

Zustand/Temper/Etat:
T6 nach/acc. to/selon DIN EN 755-1
Eloxalqualität/Anodizing quality/Qualité anodisation

Oberfläche/Surface/Etat de surface:
Preßblank/As-extruded/Brut de filage

Lagerlängen/Stock lengths/Longueur en stock:
ca./ca./env. 6000 mm

Gewicht/ Weight/ Poids.	Abwicklung/ Periphery/ Développé.	Sichtfläche/ Visible periphery/ Périmètre visible.
kg/m	mm	mm

Stoßverbindungsprofile/ Butt-joint sections/ Profils pour assemblage bout à bout

für../for../pour.. ALUCOBOND®
4 mm

Profil Nr./Section No./Profilé No.
31343

$$I_x = 0,110 \text{ cm}^4$$

$$W_x = 0,280 \text{ cm}^3$$

$$I_y = 1,008 \text{ cm}^4$$

$$W_y = 0,611 \text{ cm}^3$$

$$A = 128 \text{ mm}^2$$

M/Scale/Ech.
1:1

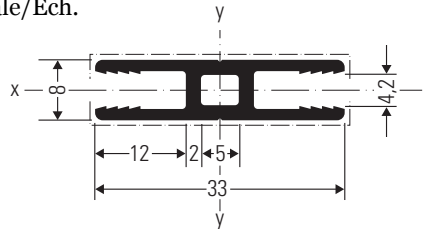

0,348	138	66
-------	-----	----

für../for../pour.. ALUCOBOND®
6 mm

Profil Nr./Section No./Profilé No.
31344

$$I_x = 0,394 \text{ cm}^4$$

$$W_x = 0,722 \text{ cm}^3$$

$$I_y = 3,740 \text{ cm}^4$$

$$W_y = 1,591 \text{ cm}^3$$

$$A = 220 \text{ mm}^2$$

M/Scale/Ech.
1:1

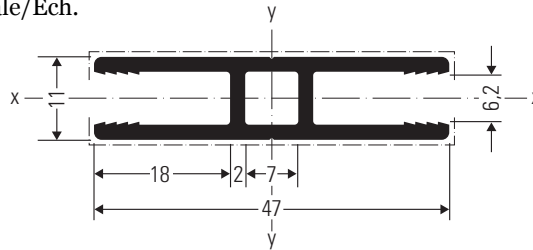

0,598	195	94
-------	-----	----

Lieferprogramm Produkt Range Gamme de produits

Werkstoff/Alloy/ Matière:
ANTICORODAL-045 (AlMgSi_{0,5}), EN AW-6060

Zustand/Temper/Etat:
T6 nach/acc. to/selon DIN EN 755-1
Eloxalqualität/Anodizing quality/Qualité anodisation

Oberfläche/Surface/Etat de surface:
Preßblank/As-extruded/Brut de filage

Lagerlängen/Stock lengths/Longueur en stock:
ca./ca./env. 6000 mm

Gewicht/ Weight/ Poids.	Abwicklung/ Periphery/ Développé.	Sichtfläche/ Visible periphery/ Périmètre visible.
kg/m	mm	mm

Einfäßprofile/ Border sections/ Profils d'encastrement

für../for../pour.. ALUCOBOND®
4 mm

Profil Nr./Section No./Profilé No.
24493

$I_x = 0,149 \text{ cm}^4$
 $W_x = 0,151 \text{ cm}^3$
 $I_y = 0,934 \text{ cm}^4$
 $W_y = 0,595 \text{ cm}^3$
 $A = 134 \text{ mm}^2$

M/Scale/Ech.
1:1

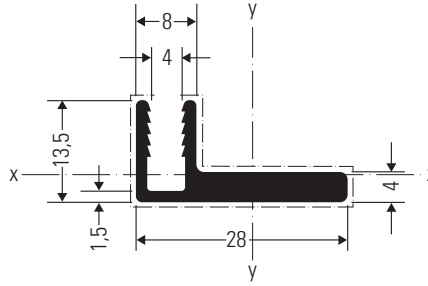

0,362	108	75
-------	-----	----

für../for../pour.. ALUCOBOND®
4 mm

Profil Nr./Section No./Profilé No.
31601

$I_x = 3,524 \text{ cm}^4$
 $W_x = 1,476 \text{ cm}^3$
 $I_y = 2,830 \text{ cm}^4$
 $W_y = 1,169 \text{ cm}^3$
 $A = 302 \text{ mm}^2$

M/Scale/Ech.
1:1

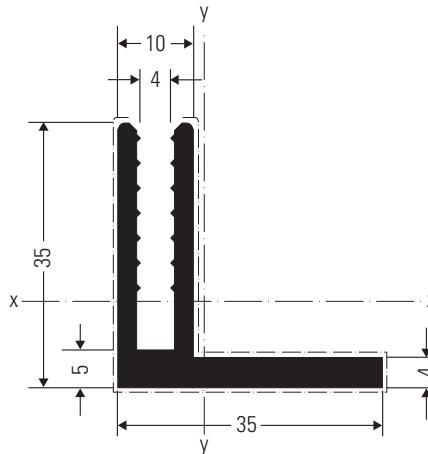

0,816	206	133
-------	-----	-----

für../for../pour.. ALUCOBOND®
6 mm

Profil Nr./Section No./Profilé No.
31998

$I_x = 3,529 \text{ cm}^4$
 $W_x = 1,474 \text{ cm}^3$
 $I_y = 2,787 \text{ cm}^4$
 $W_y = 1,176 \text{ cm}^3$
 $A = 304 \text{ mm}^2$

M/Scale/Ech.
1:1

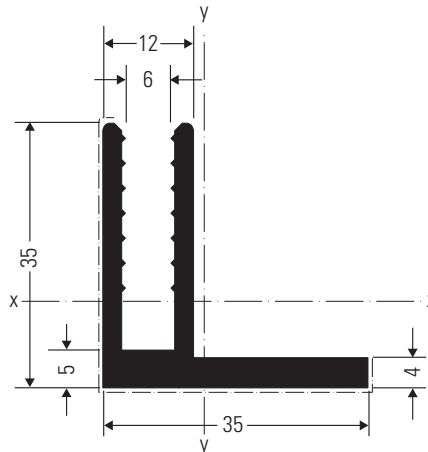

0,821	204	76
-------	-----	----

Lieferprogramm
Produkt Range
Gamme de produits

Werkstoff/Alloy/ Matière:
 ANTICORODAL-050 (AlMgSi_{0,5}), EN AW-6063

Zustand/Temper/Etat:
 T6 nach/acc. to/selon DIN EN 755-1

Oberfläche/Surface/Etat de surface:
 Preßblank/As-extruded/Brut de filage

Lagerlängen/Stock lengths/Longueur en stock:
 ca./ca./env. 6000 mm

Gewicht/ Weight/ Poids.	Abwicklung/ Periphery/ Développé.	Sichtfläche/ Visible periphery/ Périmètre visible.
kg/m	mm	mm

Tragprofil für "T 40"/
Support section for "T 40"/
Profilé porteur pour "T 40"

für../for../pour.. ALUCOBOND®
 3, 4, 6, 8 mm
Profil Nr./Section No./Profilé No.
30934

$I_x = 0,603 \text{ cm}^4$
 $W_x = 0,713 \text{ cm}^3$
 $I_y = 5,705 \text{ cm}^4$
 $W_y = 2,328 \text{ cm}^3$
 $A = 231 \text{ mm}^2$

M/Scale/Ech.
 1:1

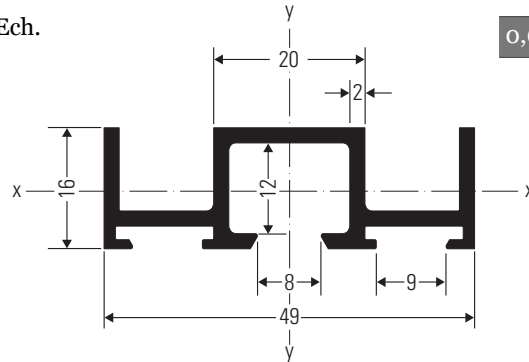

0,622	240	-
-------	-----	---

Versteifungsprofil für Balkonplatten/
Reinforcing section for Balcony Panels/
Profilé de renfort pour panneaux de balcon

für../for../pour.. ALUCOBOND®
 4 mm
Profil Nr./Section No./Profilé No.
28335

$I_x = 1,83 \text{ cm}^4$
 $W_x = 0,97 \text{ cm}^3$
 $I_y = 1,98 \text{ cm}^4$
 $W_y = 1,24 \text{ cm}^3$
 $A = 220 \text{ mm}^2$

M/Scale/Ech.
 1:1

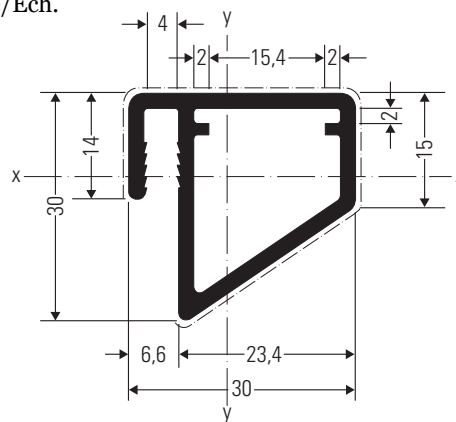

0,594	134	87
-------	-----	----

Werkstoff/Alloy/ Matière:
ANTICORODAL-045 (AlMgSi_{0,5}), EN AW-6060

Zustand/Temper/Etat:
T6 nach/acc. to/selon DIN EN 755-1
Eloxalqualität/Anodizing quality/Qualité anodisation

Oberfläche/Surface/Etat de surface:
Preßblank/As-extruded/Brut de filage

Lagerlängen/Stock lengths/Longueur en stock:
ca./ca./env. 6000 mm

Gewicht/ Weight/ Poids.	Abwicklung/ Periphery/ Développé.	Sichtfläche/ Visible periphery/ Périmètre visible.
kg/m	mm	mm

Deckprofile
Stoßverbindungsprofile – 2-teilig/
Cover sections
Butt-joint sections – 2 piece/
Profils de recouvrement
et pour assemblage bout à bout – 2 pièces



für../for../pour.. ALUCOBOND®
3, 4, 6, 8 mm
Profil Nr./Section No./Profilé No.
32651

$I_x = 0,051 \text{ cm}^4$
 $W_x = 0,124 \text{ cm}^3$
 $I_y = 2,493 \text{ cm}^4$
 $W_y = 0,959 \text{ cm}^3$
 $A = 124 \text{ mm}^2$

M/Scale/Ech.
1:1

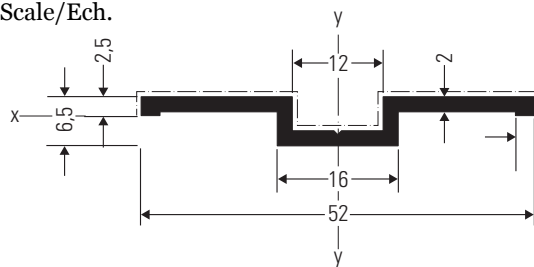

0,335	127	65
-------	-----	----

für../for../pour.. ALUCOBOND®
3, 4, 6, 8 mm
Profil Nr./Section No./Profilé No.
33842

$I_x = 0,022 \text{ cm}^4$
 $W_x = 0,044 \text{ cm}^3$
 $I_y = 2,459 \text{ cm}^4$
 $W_y = 0,945 \text{ cm}^3$
 $A = 130 \text{ mm}^2$

M/Scale/Ech.
1:1

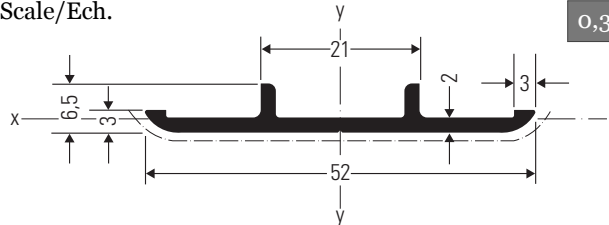

0,351	125	54
-------	-----	----

Fensteranschlußprofil/
Window connecting section/
Profilé de jonction pour fenêtre

für../for../pour.. ALUCOBOND®
4 mm
Profil Nr./Section No./Profilé No.
38464

$I_x = 0,915 \text{ cm}^4$
 $W_x = 0,561 \text{ cm}^3$
 $I_y = 0,883 \text{ cm}^4$
 $W_y = 0,412 \text{ cm}^3$
 $A = 140 \text{ mm}^2$

M/Scale/Ech.
1:1

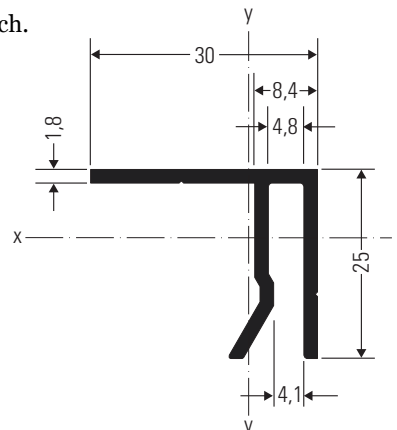

0,375	159	27
-------	-----	----

Lieferprogramm Produkt Range Gamme de produits

Werkstoff/Alloy/ Matière:
ANTICORODAL-045 (AlMgSi_{0,5}), EN AW-6060

Zustand/Temper/Etat:
T6 nach/acc. to/selon DIN EN 755-1
Eloxalqualität/Anodizing quality/Qualité anodisation

Oberfläche/Surface/Etat de surface:
Preßblank/As-extruded/Brut de filage

Lagerlängen/Stock lengths/Longueur en stock:
ca./ca./env. 6000 mm

Gewicht/ Weight/ Poids.	Abwicklung/ Periphery/ Développé.	Sichtfläche/ Visible periphery/ Périmètre visible.
kg/m	mm	mm

Hutprofile/ Hat sections/ Profils capot oméga

für../for../pour.. ALUCOBOND®
3, 4, 6, 8 mm

Profil Nr./Section No./Profilé No.

30073

$I_x = 4,50 \text{ cm}^4$

$W_x = 2,39 \text{ cm}^3$

$I_y = 12,25 \text{ cm}^4$

$W_y = 3,31 \text{ cm}^3$

$A = 294 \text{ mm}^2$

Auch für den Zusammenbau mit den Hut-
profilen Nr. 30074 und Nr. 35953 geeignet.

Also suitable for assembly with hat sections
No. 30074 and No. 35953.

Recommandé pour le montage avec profilés
capot oméga No. 30074 et No. 35953.

M/Scale/Ech.
1:1

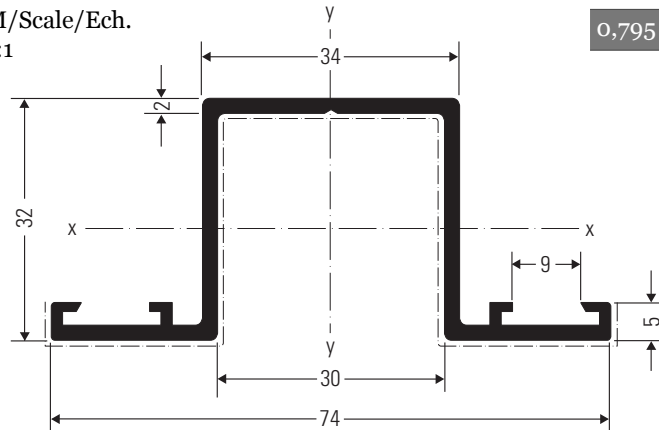

0,795	312	144
-------	-----	-----

für../for../pour.. ALUCOBOND®
3, 4, 6, 8 mm

Profil Nr./Section No./Profilé No.

33843

$I_x = 3,20 \text{ cm}^4$

$W_x = 1,80 \text{ cm}^3$

$I_y = 5,95 \text{ cm}^4$

$W_y = 1,98 \text{ cm}^3$

$A = 252 \text{ mm}^2$

M/Scale/Ech.
1:1

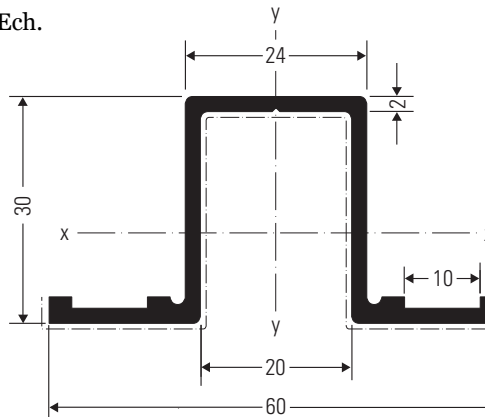

0,681	242	123
-------	-----	-----

Lieferprogramm
Produkt Range
Gamme de produits

Werkstoff/Alloy/ Matière:
 ANTICORODAL-050 (AlMgSi0,5), EN AW-6063

Zustand/Temper/Etat:
 T6 nach/acc. to/selon DIN EN 755-1

Oberfläche/Surface/Etat de surface:
 Preßblank/As-extruded/Brut de filage

Lagerlängen/Stock lengths/Longueur en stock:
 ca./ca./env. 6000 mm

Gewicht/ Weight/ Poids.	Abwicklung/ Periphery/ Développé.	Sichtfläche/ Visible periphery/ Périmètre visible.
kg/m	mm	mm

**Hutprofile/
 Hat sections/
 Profilés capot oméga**

für../for../pour.. ALUCOBOND®
 3, 4, 6, 8 mm
Profil Nr./Section No./Profilé No.
35951

$I_x = 5,80 \text{ cm}^4$
 $W_x = 2,98 \text{ cm}^3$
 $I_y = 14,01 \text{ cm}^4$
 $W_y = 3,77 \text{ cm}^3$
 $A = 289 \text{ mm}^2$

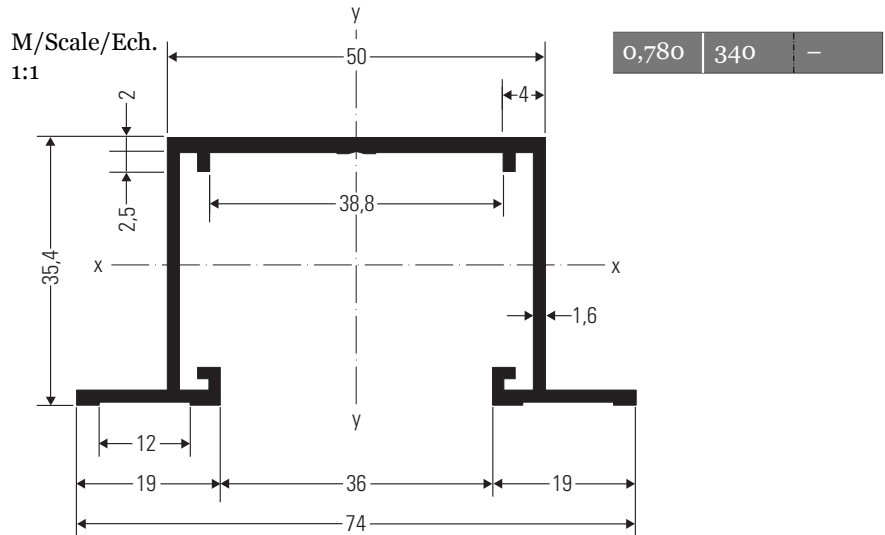

**Hutprofile/
 Hat sections/
 Profilés capot oméga**

für../for../pour.. ALUCOBOND®
 3, 4, 6, 8 mm
Profil Nr./Section No./Profilé No.
30465

$I_x = 6,37 \text{ cm}^4$
 $W_x = 2,98 \text{ cm}^3$
 $I_y = 7,38 \text{ cm}^4$
 $W_y = 2,46 \text{ cm}^3$
 $A = 288 \text{ mm}^2$

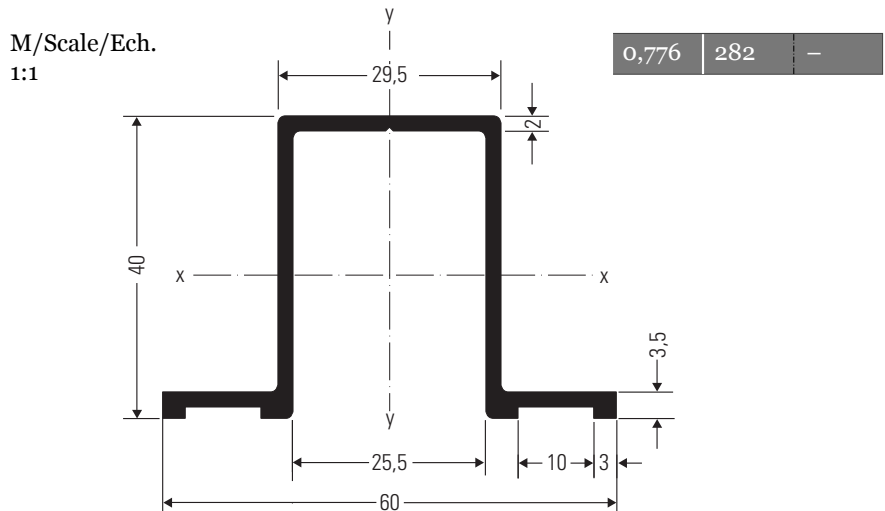

Lieferprogramm
Produkt Range
Gamme de produits

Werkstoff/Alloy/ Matière:
 ANTICORODAL-050 (AlMgSi_{0,5}), EN AW-6063

Zustand/Tempér/Etat:
 T6 nach/acc. to/selon DIN EN 755-1

Oberfläche/Surface/Etat de surface:
 Preßblank/As-extruded/Brut de filage

Lagerlängen/Stock lengths/Longueur en stock:
 ca./ca./env. 6000 mm

Gewicht/ Weight/ Poids.	Abwicklung/ Periphery/ Développé.	Sichtfläche/ Visible periphery/ Périmètre visible.
kg/m	mm	mm

**Hutprofile/
 Hat sections/
 Profilés capot oméga**

für../for../pour.. ALUCOBOND®
 3, 4, 6, 8 mm
Profil Nr./Section No./Profilé No.
30074

$I_x = 3,41 \text{ cm}^4$
 $W_x = 2,26 \text{ cm}^3$
 $I_y = 12,69 \text{ cm}^4$
 $W_y = 3,43 \text{ cm}^3$
 $A = 274 \text{ mm}^2$

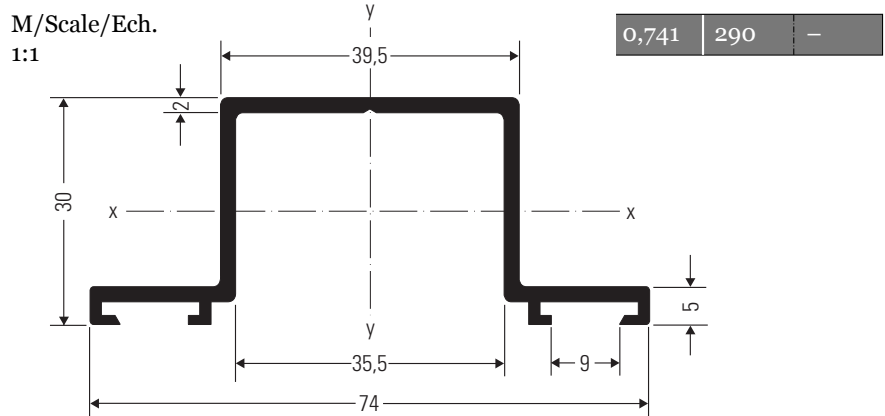

für../for../pour.. ALUCOBOND®
 3, 4, 6, 8 mm
Profil Nr./Section No./Profilé No.
35953

$I_x = 16,31 \text{ cm}^4$
 $W_x = 5,81 \text{ cm}^3$
 $I_y = 28,08 \text{ cm}^4$
 $W_y = 5,85 \text{ cm}^3$
 $A = 396 \text{ mm}^2$

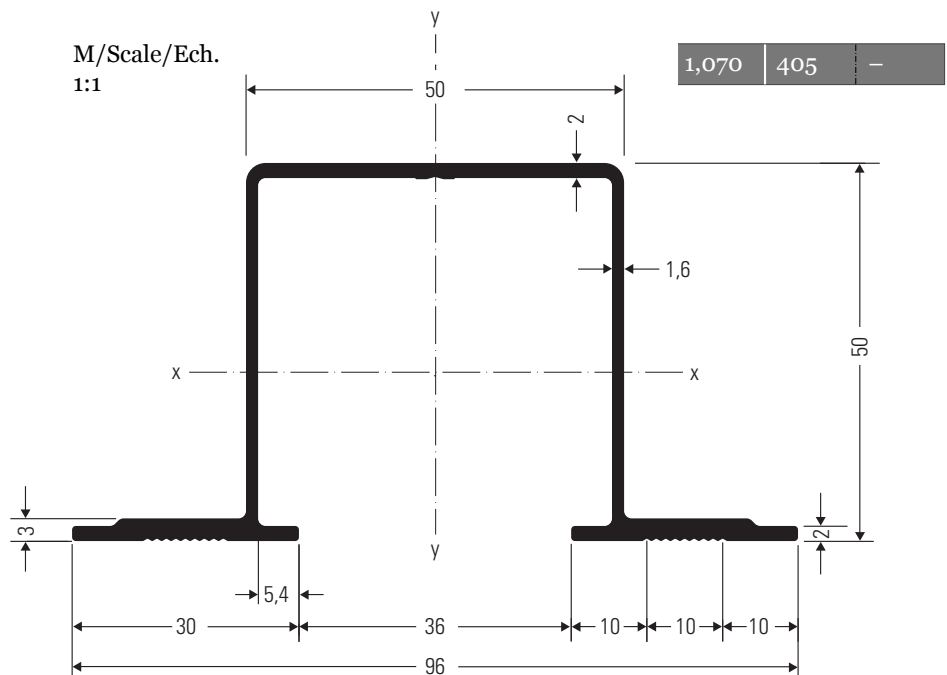

Lieferprogramm
Produkt Range
Gamme de produits

Werkstoff/Alloy/ Matière:
 ANTICORODAL-050 (AlMgSi_{0,5}), EN AW-6063

Zustand/Temper/Etat:
 T6 nach/acc. to/selon DIN EN 755-1

Oberfläche/Surface/Etat de surface:
 Preßblank/As-extruded/Brut de filage

Lagerlängen/Stock lengths/Longueur en stock:
 ca./ca./env. 6000 mm

Gewicht/ Weight/ Poids.	Abwicklung/ Periphery/ Développé.	Sichtfläche/ Visible periphery/ Périmètre visible.
kg/m	mm	mm

ECOCLAD
T-Profil/
T-Section/
Profilé T

für../for../pour.. ALUCOBOND®
 3, 4, 6, 8 mm
Profil Nr./Section No./Profilé No.
39951

$I_x = 6,12 \text{ cm}^4$
 $W_x = 1,53 \text{ cm}^3$
 $I_y = 25,33 \text{ cm}^4$
 $W_y = 4,22 \text{ cm}^3$
 $A = 313 \text{ mm}^2$

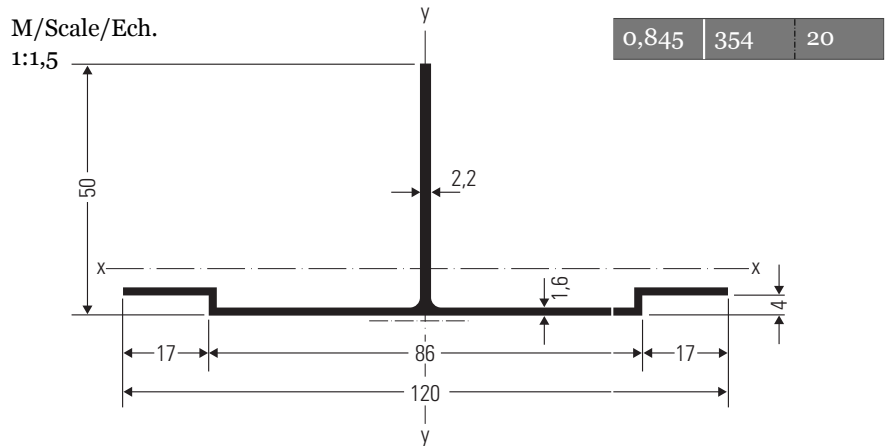

ECOCLAD
Pi-Profil/
Pi-Section/
Profilé Pi

für../for../pour.. ALUCOBOND®
 3, 4, 6, 8 mm
Profil Nr./Section No./Profilé No.
41775

$I_x = 33,29 \text{ cm}^4$
 $W_x = 7,40 \text{ cm}^3$
 $I_y = 70,03 \text{ cm}^4$
 $W_y = 10,00 \text{ cm}^3$
 $A = 655 \text{ mm}^2$

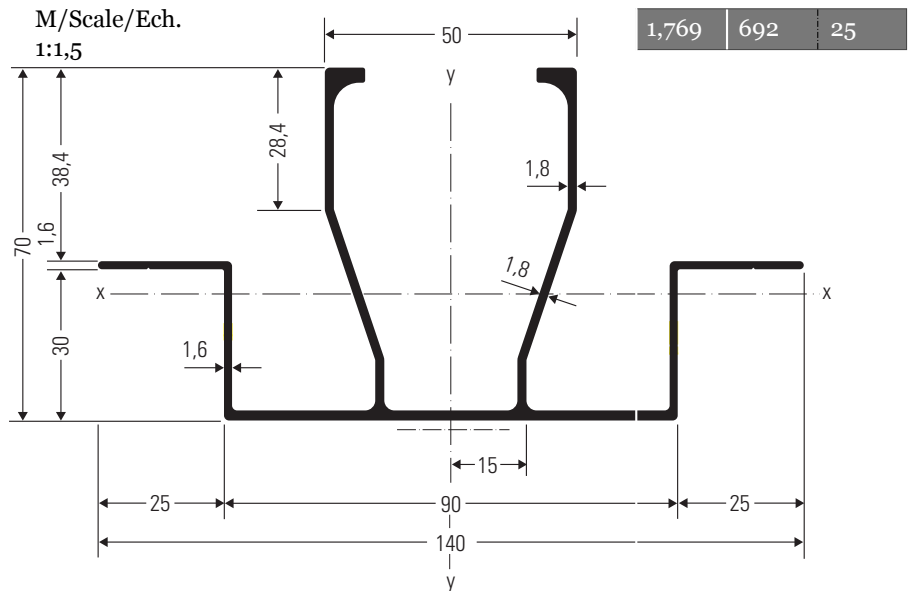

Lieferprogramm
Produkt Range
Gamme de produits

Werkstoff/Alloy/ Matière:
 ANTICORODAL-050 (AlMgSi0,5), EN AW-6063

Zustand/Temper/Etat:
 T6 nach/acc. to/selon DIN EN 755-1

Oberfläche/Surface/Etat de surface:
 Preßblank/As-extruded/Brut de filage

Lagerlängen/Stock lengths/Longueur en stock:
 ca./ca./env. 6000 mm

Gewicht/ Weight/ Poids.	Abwicklung/ Periphery/ Développé.	Sichtfläche/ Visible periphery/ Périmètre visible.
kg/m	mm	mm

ECOCLAD
Queranschlußprofil für Profile
39951 und 41775/
Cross-section for sections
No. 39951 and 41775/
Profilé transversal pour
No. 39951 et 41775

für../for../pour.. ALUCOBOND®
 3, 4, 6, 8 mm
Profil Nr./Section No./Profilé No.
41649

$I_x = 9,01 \text{ cm}^4$
 $W_x = 6,00 \text{ cm}^3$
 $I_y = 93,33 \text{ cm}^4$
 $W_y = 12,44 \text{ cm}^3$
 $A = 537 \text{ mm}^2$

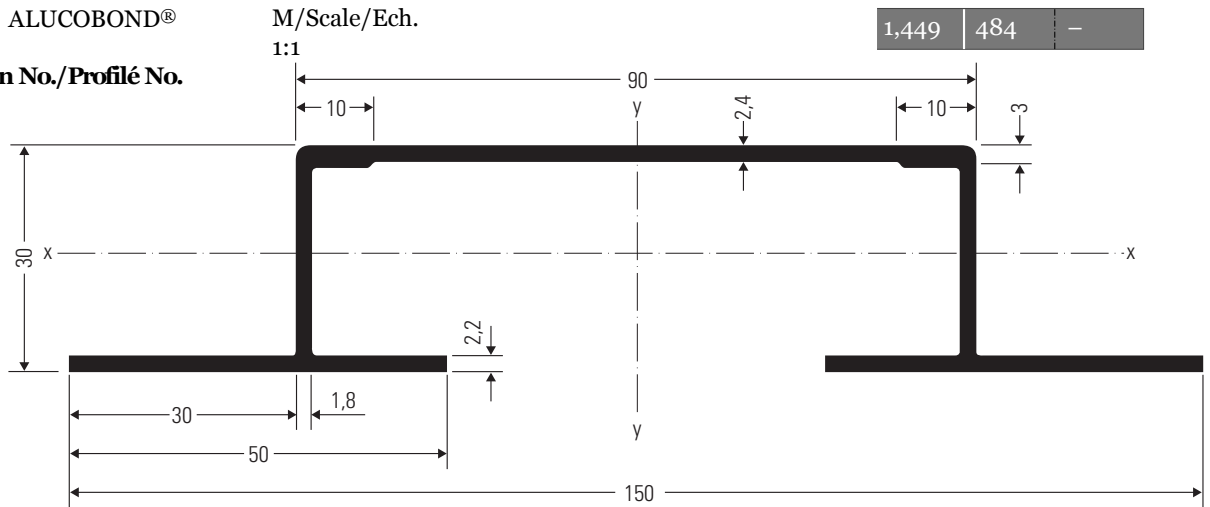

ECOCLAD
Queranschlußprofil für Profile
39951 und 41775/
Cross-section for sections
No. 39951 and 41775/
Profilé transversal pour
No. 39951 et 41775

für../for../pour.. ALUCOBOND®
 3, 4, 6, 8 mm
Profil Nr./Section No./Profilé No.
41642

$I_x = 5,02 \text{ cm}^4$
 $W_x = 3,06 \text{ cm}^3$
 $I_y = 13,59 \text{ cm}^4$
 $W_y = 2,92 \text{ cm}^3$
 $A = 298 \text{ mm}^2$

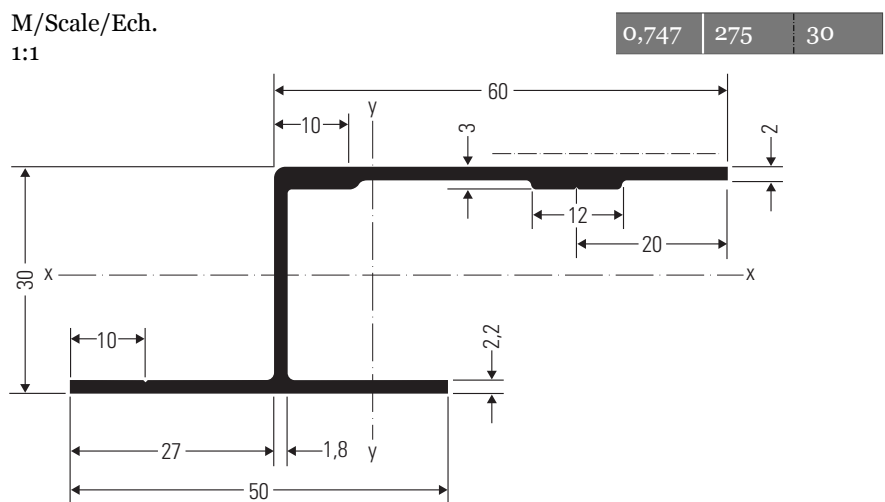

Lieferprogramm
Produkt Range
Gamme de produits

Werkstoff/Alloy/ Matière:
 ANTICORODAL-050 (AlMgSi0,5), EN AW-6063

Zustand/Temper/Etat:
 T6 nach/acc. to/selon DIN EN 755-1

Oberfläche/Surface/Etat de surface:
 Preßblank/As-extruded/Brut de filage

Lagerlängen/Stock lengths/Longueur en stock:
 ca./ca./env. 6000 mm

Gewicht/ Weight/ Poids.	Abwicklung/ Periphery/ Développé.	Sichtfläche/ Visible periphery/ Périmètre visible.
kg/m	mm	mm

ECOCLAD
Omegaprofil/
Omega-section/
Profilé Oméga

für../for../pour.. ALUCOBOND®
 3, 4, 6, 8 mm
Profil Nr./Section No./Profilé No.
42530

$I_x = 17,20 \text{ cm}^4$
 $W_x = 5,65 \text{ cm}^3$
 $I_y = 55,62 \text{ cm}^4$
 $W_y = 8,24 \text{ cm}^3$
 $A = 496 \text{ mm}^2$

M/Scale/Ech.
 1:1

1,341	616	-
-------	-----	---

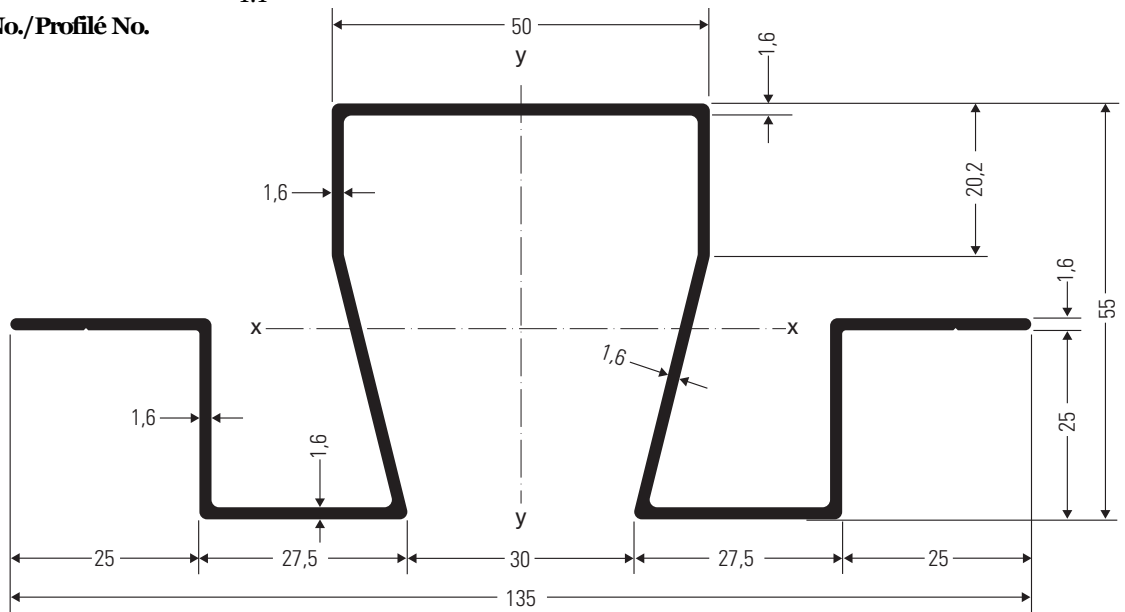

Lieferprogramm
Produkt Range
Gamme de produits

Werkstoff/Alloy/ Matière:
 ANTICORODAL-050 (AlMgSi_{0,5}), EN AW-6063

Zustand/Temper/Etat:
 T6 nach/acc. to/selon DIN EN 755-1

Oberfläche/Surface/Etat de surface:
 Preßblank/As-extruded/Brut de filage

Lagerlängen/Stock lengths/Longueur en stock:
 ca./ca./env. 6000 mm

Gewicht/ Weight/ Poids.	Abwicklung/ Periphery/ Développé.	Sichtfläche/ Visible periphery/ Périmètre visible.
kg/m	mm	mm

ECOCLAD
Queranschlußprofil für Profile
39951 und 42530/
Cross-section for sections
No. 39951 and 42530/
Profilé transversal pour
No. 39951 et 42530

für../for../pour.. ALUCOBOND®
 3, 4, 6, 8 mm
Profil Nr./Section No./Profilé No.

M/Scale/Ech.
 1:1

0,976	413	25
-------	-----	----

42531

$I_x = 4,16 \text{ cm}^4$
 $W_x = 3,31 \text{ cm}^3$
 $I_y = 49,07 \text{ cm}^4$
 $W_y = 7,27 \text{ cm}^3$
 $A = 360 \text{ mm}^2$

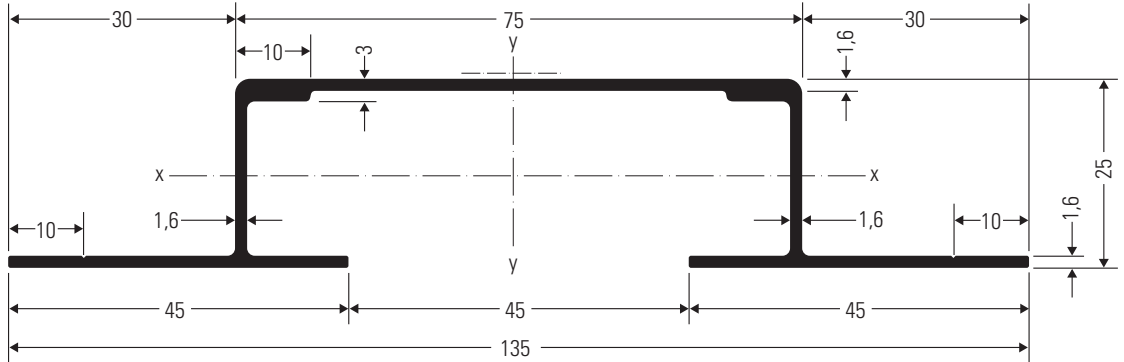

ECOCLAD
Queranschlußprofil für Profile
39951 und 42530/
Cross-section for sections
No. 39951 and 42530/
Profilé transversal pour
No. 39951 et 42530

für../for../pour.. ALUCOBOND®
 3, 4, 6, 8 mm
Profil Nr./Section No./Profilé No.

M/Scale/Ech.
 1:1

0,796	264	25
-------	-----	----

42532

$I_x = 3,36 \text{ cm}^4$
 $W_x = 2,42 \text{ cm}^3$
 $I_y = 17,89 \text{ cm}^4$
 $W_y = 3,44 \text{ cm}^3$
 $A = 294 \text{ mm}^2$

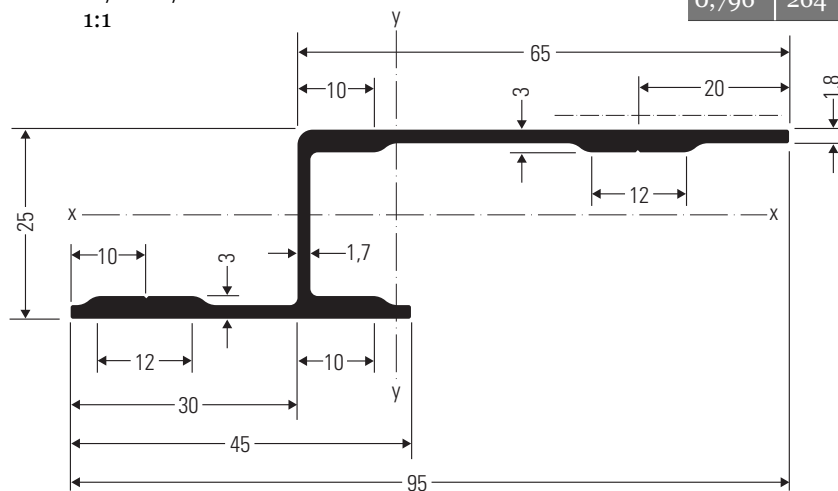

Lieferprogramm Produkt Range Gamme de produits

Werkstoff/Alloy/ Matière:
ANTICORODAL-050 (AlMgSi_{0,5}), EN AW-6063

Zustand/Temper/Etat:
T6 nach/acc. to/selon DIN EN 755-1

Oberfläche/Surface/Etat de surface:
Preßblank/As-extruded/Brut de filage

Lagerlängen/Stock lengths/Longueur en stock:
ca./ca./env. 6000 mm

Gewicht/ Weight/ Poids.	Abwicklung/ Periphery/ Développé.	Sichtfläche/ Visible periphery/ Périmètre visible.
kg/m	mm	mm

Kassettenprofile Befestigungsprinzip SZ 20 – 2-teilig/ Sections for tray panels Fixing principle SZ 20 – 2 piece/ Profils pour cassettes Principe de fixation SZ 20 – 2 pièces

für./for./pour.. ALUCOBOND®
4 mm

M/Scale/Ech.
1:2

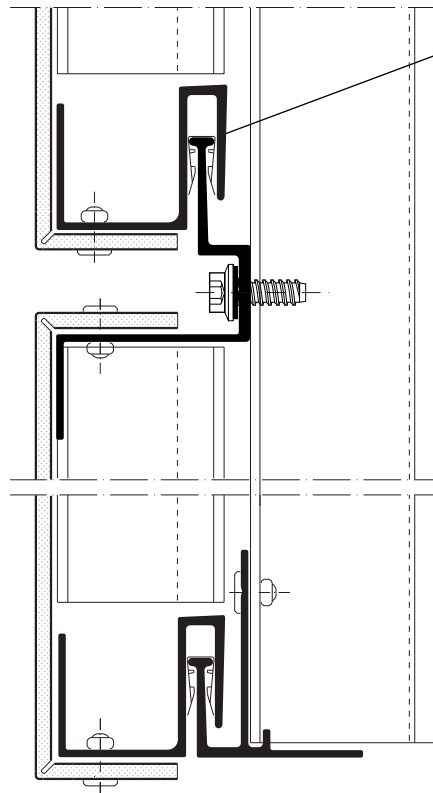

Kunststoff-Clips/
Plastic clip/
Clip en matière plastique
SZ 20

Länge/Length/Longueur
40 mm

Artikel Nr./Article No./
Article No.
MO 2061

für./for./pour.. ALUCOBOND®
4 mm

S-Profil Nr./S-Section No./
Profilé S No.

44024

$I_x = 3,21 \text{ cm}^4$

$W_x = 1,68 \text{ cm}^3$

$I_y = 5,30 \text{ cm}^4$

$W_y = 2,28 \text{ cm}^3$

$A = 247 \text{ mm}^2$

M/Scale/Ech.
1:1

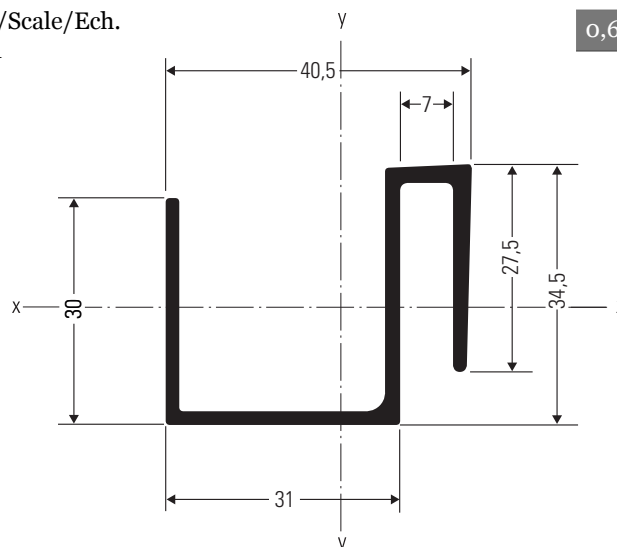

0,667	251	—
-------	-----	---

Lieferprogramm
Produkt Range
Gamme de produits

Werkstoff/Alloy/ Matière:
 ANTICORODAL-050 (AlMgSi_{0,5}), EN AW-6063

Zustand/Temper/Etat:
 T6 nach/acc. to/selon DIN EN 755-1

Oberfläche/Surface/Etat de surface:
 Preßblank/As-extruded/Brut de filage

Lagerlängen/Stock lengths/Longueur en stock:
 ca./ca./env. 6000 mm

Gewicht/ Weight/ Poids.	Abwicklung/ Periphery/ Développé.	Sichtfläche/ Visible periphery/ Périmètre visible.
kg/m	mm	mm

Kassettenprofile
Befestigungsprinzip SZ 20 – 2-teilig
Sections for tray panels
Fixing principle SZ 20 – 2 piece
Profils pour cassettes
Principe de fixation SZ 20 – 2 pièces

für../for../pour.. ALUCOBOND®
 4 mm
Profil Nr./Section No./Profilé No.
44025

$I_x = 8,12 \text{ cm}^4$
 $W_x = 2,20 \text{ cm}^3$
 $I_y = 6,80 \text{ cm}^4$
 $W_y = 2,42 \text{ cm}^3$
 $A = 269 \text{ mm}^2$

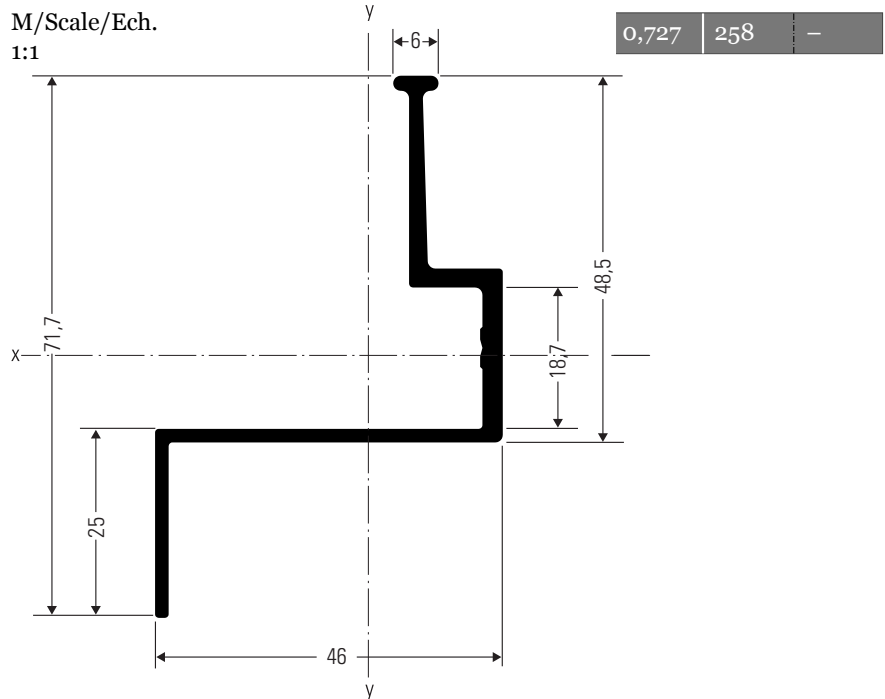

für../for../pour.. ALUCOBOND®
 4 mm
Basis-Profil für SZ 20-System/
Base section for SZ 20-system/
Profilé de base pour système SZ 20
44026

$I_x = 4,58 \text{ cm}^4$
 $W_x = 1,25 \text{ cm}^3$
 $I_y = 2,13 \text{ cm}^4$
 $W_y = 0,75 \text{ cm}^3$
 $A = 231 \text{ mm}^2$

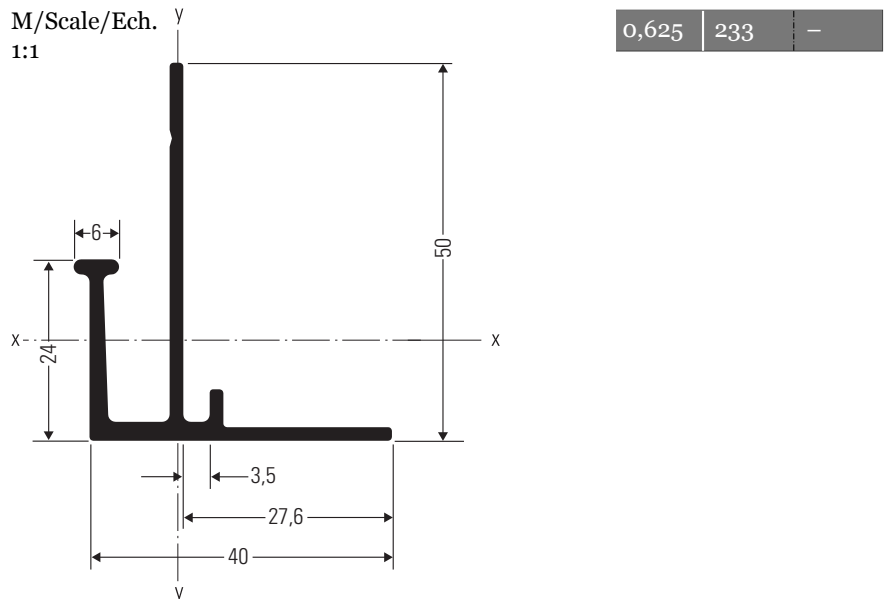

ALUCOBOND®



3A Composites GmbH
Alusingenplatz 1
D-78224 Singen, Germany
Tel. +49 (0) 7731 80 20 60
info.eu@alucobond.com
www.alucobond.com